

Pompa tipo GP-GPM 45EV-65EV

Pump type GP-GPM 45EV-65EV

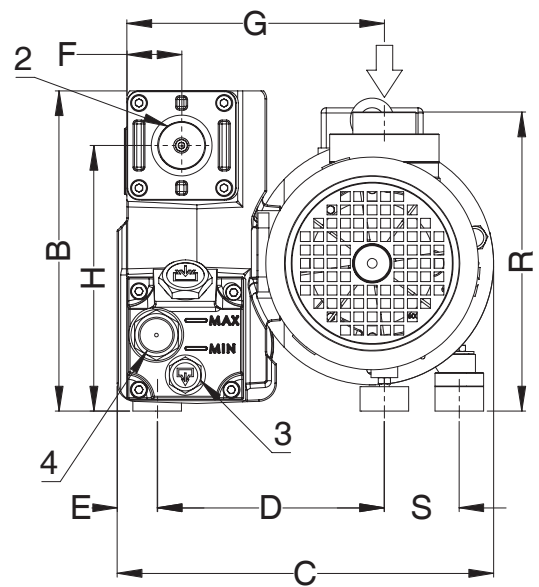
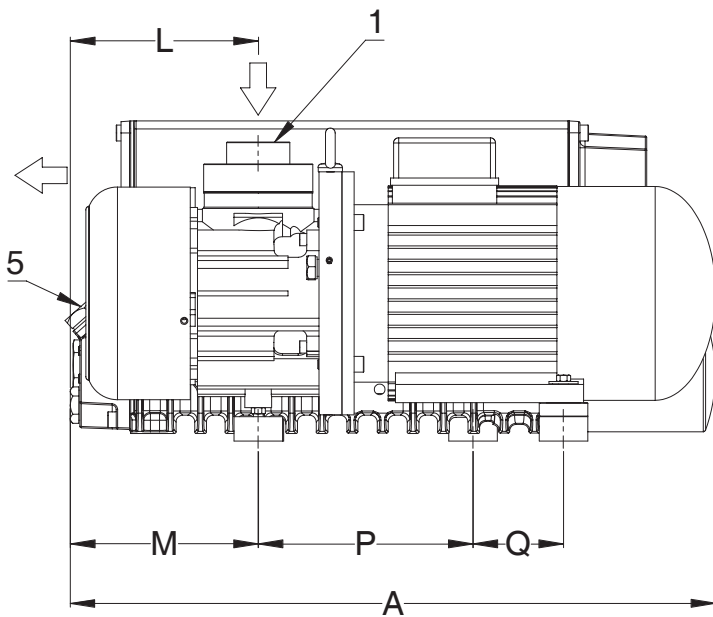

1 Aspirazione
 2 Scarico
 3 Tappo scarico olio
 4 Spia livello olio
 5 Tappo carico olio

1 Suction
 2 Discharge
 3 Oil discharge plug
 4 Oil sight glass
 5 Oil fill up plug

	Dimensioni (mm) Dimension (mm)													
GP-GPM	A	B	C	D	E	F	G	H	L	M	P	Q	R	S
45EV	530	264	310	187	33	45	212	219	155	155	177	58	246	62
65EV	530	264	310	187	33	45	212	219	155	155	177	98	246	62

