

Pompa tipo GP-GP/M 160-210K

Pump type GP-GP/M 160-210K

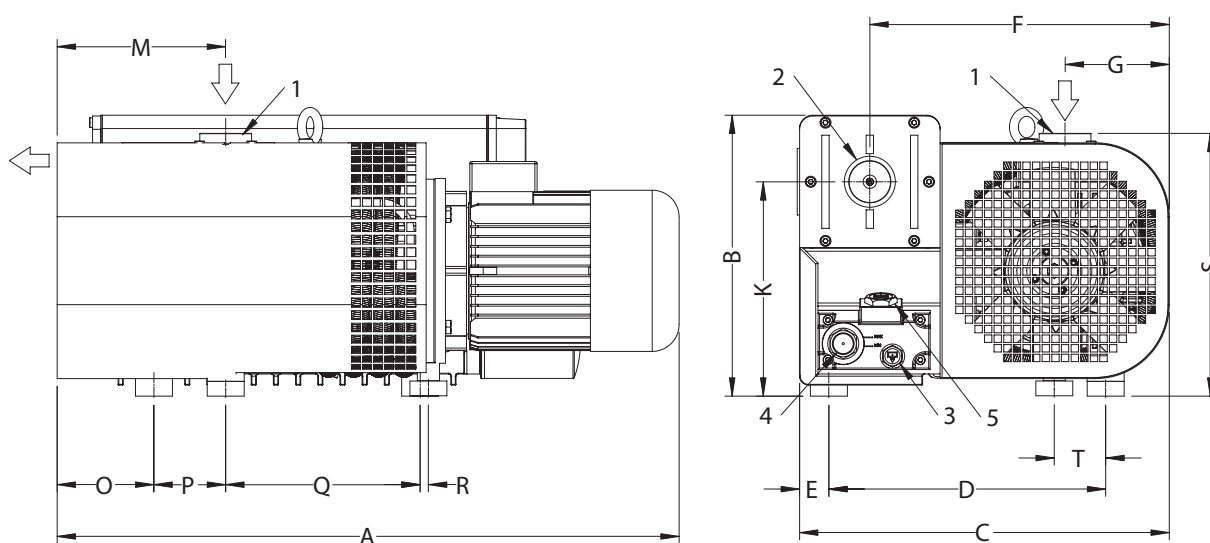
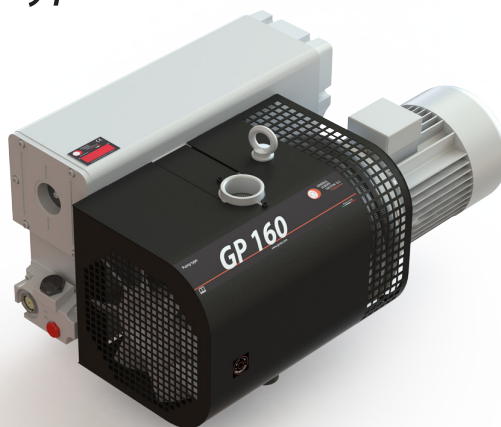

1 Aspirazione
 2 Scarico
 3 Tappo scarico olio
 4 Spia livello olio
 5 Tappo carico olio

1 Suction
 2 Discharge
 3 Oil discharge plug
 4 Oil sight glass
 5 Oil fill up plug

GP-GP/M	Dimensioni (mm) Dimension (mm)														
	A	B	C	D	E	F	G	K	M	O	P	Q	R	S	T
160	815	380	502	375	38	406	143	290	215	118	97	261	0	355	69
210K	841	380	502	375	38	406	143	290	215	118	97	261	11	355	69

