

Pompa tipo GP-GP/M 100 ATEX

Pump type GP-GP/M 100 ATEX

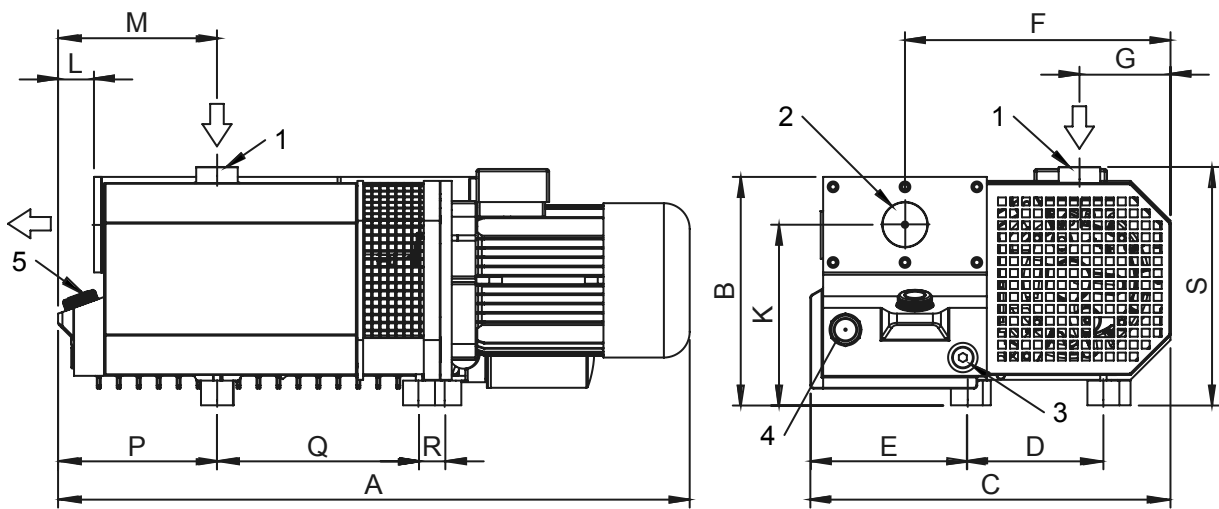

- 1 Aspirazione
- 2 Scarico
- 3 Tappo scarico olio
- 4 Spia livello olio
- 5 Tappo carico olio

- 1 Suction
- 2 Discharge
- 3 Oil discharge plug
- 4 Oil sight glass
- 5 Oil fill up plug

	Dimensioni (mm) Dimension (mm)													
GP-GP/M	A	B	C	D	E	F	G	H	L	M	P	Q	R	S
100	810	280	445	165	200	330	110	220	55	200	200	250	35	275

50 Hz

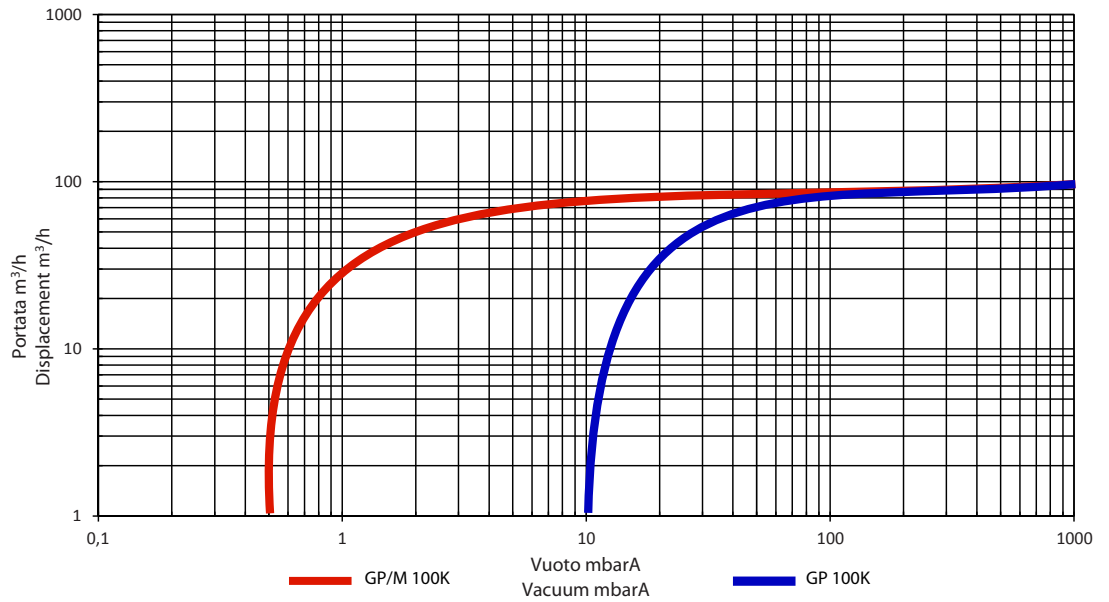

60 Hz

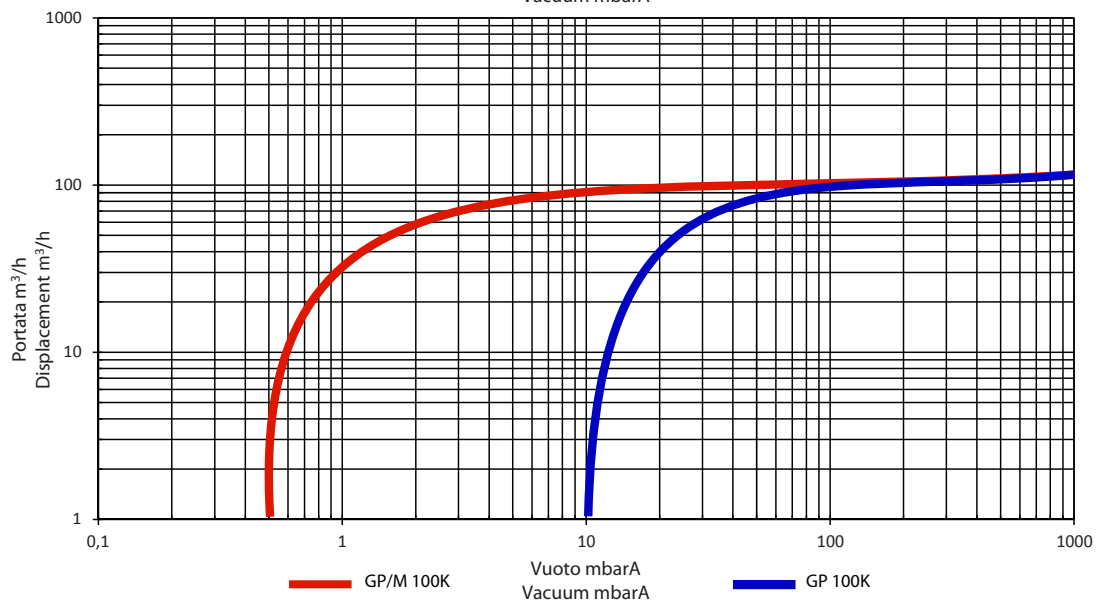

			Tipo di pompa/Frequenza Pump type/Frequency			
			GP100 50Hz	GP100 60Hz	GP/M100 50Hz	GP/M100 60Hz
Portata nominale	<i>Displacement</i>	m ³ /h	100	120	100	120
Vuoto finale	<i>Ultimate vacuum</i>	mbar	10	10	0,5	0,5
Rumorosità media senza zavorratore	<i>Noise level without gas ballast</i>	db (A)	70	74	70	74
Vuoto finale con zavorratore	<i>Ultimate vacuum with gas ballast</i>	mbar	14	14	1,5	1,5
Quantità max di vapore d'acqua tollerabile con zavorratore	<i>Max water vapour quantity acceptable with gas ballast</i>	kg/h	1,7	2	1,7	2
Tensione standard	<i>Standard voltage</i>	V	230/400	460	230/400	460
Potenza motore	<i>Motor power</i>	kW	2,2	3	2,2	3
Velocità di rotazione	<i>R.P.M.</i>	g/1'	1450	1750	1450	1750
Peso con olio	<i>Weight with oil</i>	kg	98	98	98	98
Quantità d'olio	<i>Oil quantity</i>	l	5	5	5	5
Attacco aspirazione	<i>Inlet connection</i>		1¼" GAS	1¼" GAS	1¼" GAS	1¼" GAS
Attacco scarico	<i>Outlet connection</i>		2" GAS	2" GAS	2" GAS	2" GAS